

1. Fundamental and derivate quantities and units

- Fundamental Physical quantities are those that can be directly defined, and for which the units are chosen arbitrarily, independent of others physical quantities.

No.	Fundamental Quantity	Unit	Symbol	Dimension
1	Length	Meter	m	L
2	Time	Second	s	T
3	Mass	Kilogram	kg	M
4	Current intensity	Ampere	A	I
5	Light intensity	Candela	Cd	J
6	Temperature	Kelvin	K	θ
<hr style="border-top: 1px dashed black;"/>				
7	Solid angle	Ste-radian	Sr	
8	Plane angle	Radian	rad	

- The derivative physical quantities are those that are defined indirectly. They have the measurement units' functions of fundamental units.

If we have:

- $U = U(L, T, M, I, J, \theta)$
- $[U] = L^\alpha T^\beta M^\gamma I^\delta J^\epsilon \theta^\xi$

2 The homogeneity of physical equations:

- The physical formulas are invariant to the measurement units' transformation.

3 Examples:

3.1 Velocity:

$$v = \lim_{\Delta t \rightarrow 0} \frac{\Delta x}{\Delta t} = \frac{dx}{dt} \quad [v] = \frac{[x]}{[t]} = \frac{m}{s} = m \cdot s^{-1} = L \cdot T^{-1} \quad (1)$$

3.2 Acceleration:

$$a = \lim_{\Delta t \rightarrow 0} \frac{\Delta v}{\Delta t} = \frac{dv}{dt} \quad [a] = \frac{[v]}{[t]} = \frac{m}{s^2} = m \cdot s^{-2} = L \cdot T^{-2} \quad (2)$$

3.3 Impulse:

$$p = m \cdot v \quad [p] = [m] \cdot [v] = kg \frac{m}{s} = kg \cdot m \cdot s^{-1} = M \cdot L \cdot T^{-1} \quad (3)$$

3.4 Force:

$$F = \lim_{\Delta t \rightarrow 0} \frac{\Delta p}{\Delta t} = \frac{dp}{dt} = \frac{dmv}{dt} = m \frac{dv}{dt} = m \cdot a$$

$$[F] = \frac{[p]}{[t]} = \frac{\text{kg} \cdot \text{m}}{\text{s}^2} = \text{kg} \cdot \text{m} \cdot \text{s}^{-2} = \text{M} \cdot \text{L} \cdot \text{T}^{-2} \quad [F] = 1 \frac{\text{kg} \cdot \text{m}}{\text{s}^2} = 1\text{N} \quad (4)$$

3.5 Pressure:

$$P = \frac{dF}{dS} \quad [P] = \frac{[F]}{[S]} = \frac{\text{kg}}{\text{s}^2 \cdot \text{m}} = \text{kg} \cdot \text{m}^{-1} \cdot \text{s}^{-2} = \text{M} \cdot \text{L}^{-1} \cdot \text{T}^{-2} \quad [P] = 1 \frac{\text{N}}{\text{m}^2} = 1\text{Pa} \quad (5)$$

3.6 Mechanical work:

$$dL = F \cdot ds \quad [L] = [F] \cdot [s] = \text{kg} \frac{\text{m}^2}{\text{s}^2} = \text{kg} \cdot \text{m}^2 \cdot \text{s}^{-2} = \text{M} \cdot \text{L}^2 \cdot \text{T}^{-2} \quad [L] = 1\text{N} \cdot \text{m} = 1\text{J} \quad (6)$$

3.7 Kinetic energy:

$$E_c = \frac{m \cdot v^2}{2};$$

$$[E_c] = [m][v]^2 = \frac{\text{kg} \cdot \text{m}^2}{\text{s}^2} = \text{kg} \cdot \text{m}^2 \cdot \text{s}^{-2} = \text{M} \cdot \text{L}^2 \cdot \text{T}^{-2}; \quad [E_c] = 1\text{kg} \cdot \text{m}^2 \cdot \text{s}^{-2} = 1\text{J} \quad (7)$$

3.8 Gravitational potential Energy:

$$E_p = m \cdot g \cdot h$$

$$[E_p] = [m] \cdot [g] \cdot [h] = \text{kg} \frac{\text{m}^2}{\text{s}^2} = \text{kg} \cdot \text{m}^2 \cdot \text{s}^{-2} = \text{M} \cdot \text{L}^2 \cdot \text{T}^{-2}; \quad [E_p] = 1\text{kg} \cdot \text{m}^2 \cdot \text{s}^{-2} = 1\text{J} \quad (8)$$

3.9 Elastically potential Energy:

$$E_{p,e} = \frac{k \cdot x^2}{2}$$

$$[E_{p,e}] = [k][x]^2 = \frac{\text{kg} \cdot \text{m}^2}{\text{s}^2} = \text{kg} \cdot \text{m}^2 \cdot \text{s}^{-2} = \text{M} \cdot \text{L}^2 \cdot \text{T}^{-2}; \quad [E_{p,e}] = 1\text{kg} \cdot \text{m}^2 \cdot \text{s}^{-2} = 1\text{J} \quad (9)$$

3.10 Power:

$$P = \frac{dE}{dt}$$

$$[P] = \frac{[E]}{[t]} = \frac{\text{kg} \cdot \text{m}^2}{\text{s}^3} = \text{kg} \cdot \text{m}^2 \cdot \text{s}^{-3} = \text{M} \cdot \text{L}^2 \cdot \text{T}^{-3} \quad [P] = 1 \frac{\text{J}}{\text{s}} = 1\text{W} \quad (10)$$

3.11 Density:

$$\rho = \frac{dm}{dV} \quad [\rho] = \frac{[m]}{[V]} = \frac{\text{kg}}{\text{m}^3} = \text{kg} \cdot \text{m}^{-3} = \text{M} \cdot \text{L}^{-3} \quad (11)$$

3.12 Angular velocity:

$$\omega = \frac{d\phi}{dt} \quad [\omega] = \frac{[\phi]}{[t]} = \frac{\text{rad}}{\text{s}} = \text{rad} \cdot \text{s}^{-1} = \text{T}^{-1} \quad (12)$$

3.13 Solid angle:

$$d\Omega = \frac{dA}{R^2} \quad [\Omega] = \frac{[A]}{[R]^2} = \frac{\text{m}^2}{\text{m}^2} = \text{L}^0 = 1 \quad [\Omega] = 1\text{L}^0 = 1\text{steradian} \quad (13)$$

4 Establishes into a constant approximation the formula of a gravitational (mathematical) pendulum, T using the homogeneity of the dimensional equations.

R: From direct observation the physical quantities that can occur are: the length (l), mass of the pendulum (m), gravitational acceleration (g).

$$T = k l^\alpha m^\beta g^\gamma$$

$T^1 = k^0 \cdot L^\alpha \cdot M^\beta \cdot (L \cdot T^{-2})^\gamma \Rightarrow T^1 = L^{\alpha+\gamma} \cdot M^\beta \cdot T^{-2\gamma}$, then by identifying the upper coefficients:

$$\begin{cases} \alpha + \gamma = 0 \\ \beta = 0 \\ -2\gamma = 1 \end{cases} \Rightarrow \begin{cases} \alpha = \frac{1}{2} \\ \beta = 0 \\ \gamma = -\frac{1}{2} \end{cases} \quad T = k l^{1/2} m^0 g^{-1/2} \Rightarrow T = k \sqrt{\frac{l}{g}}$$

5 The mass of a parachute with jumper (parachutist) is $m = 100 \text{ kg}$, and is launched from a tower completely open with no initial velocity. Find the velocity expression, $v(t)$ and the velocity limit if we know that the resistance force is proportional with the velocity, $R = kv$, where $k = 500 \text{ Ns/m}$.

R: If the force is defined as: $\vec{F} = m\vec{a}$

Along vertical direction can be rewritten as: $F = m \frac{dv}{dt}$

The resultant (net) force is $F = G - R$, then:

$$m \frac{dv}{dt} = mg - kv \Rightarrow \int_{v(0)}^{v(t)} \frac{dv}{g - \frac{k}{m}v} = \int_0^t dt' \Rightarrow -\frac{m}{k} \ln \left(g - \frac{k}{m}v \right) \Big|_{v(0)}^{v(t)} = t \xrightarrow{v(0)=0} \ln \left(1 - \frac{k}{mg}v(t) \right) = -\frac{k}{m}t$$

$$\Rightarrow v(t) = \frac{mg}{k} \left(1 - e^{-\frac{k}{m}t} \right).$$

If we will replace the physical quantities with values we get:

$$v(t) = \frac{100 \cdot 10}{500} \left(1 - e^{-\frac{500}{100}t} \right) \Rightarrow v(t) = 2(1 - e^{-5t}) \left[\frac{\text{m}}{\text{s}} \right]$$

For the time goes to infinity one obtains:

$$v_{\lim} = \lim_{t \rightarrow \infty} v(t) = \lim_{t \rightarrow \infty} \left\{ \frac{mg}{k} \left(1 - e^{-\frac{k}{m}t} \right) \right\} \Rightarrow v_{\lim} = \frac{mg}{k} = \frac{100 \cdot 10}{500} \Rightarrow v_{\lim} = 2 \frac{\text{m}}{\text{s}} = 7.2 \frac{\text{km}}{\text{h}}$$

Finally the velocity expression can be written as:

$$v(t) = v_{\lim} \left(1 - e^{-\frac{k}{m}t} \right)$$

6. A skier with the weight G descends a hill that make an angle α with the horizontal plane. The motion equations are $x = Agt^2$ along the hill and $y = 0$, where g is the gravitational acceleration and A a constant coefficient. How much is the friction force between skier and snow on the hill. (Particular case: the skier mass $m = 70$ kg, angle $\alpha = 30^\circ$; $A = 0.1$).

R: The second principle of dynamics can be written as:

$$\vec{G} + \vec{R} + \vec{F}_f = m\vec{a}$$

The projections along x and y axes are:

$$G \sin(\alpha) - F_f = ma_x$$

$$R - G \cos(\alpha) = ma_y$$

The component of accelerations can be calculated with the following equations:

$$a_x = \frac{d^2x}{dt^2} = \frac{d^2(Agt^2)}{dt^2} = 2Ag$$

$$a_y = \frac{d^2y}{dt^2} = \frac{d^2(0)}{dt^2} = 0$$

With those:

$$F_f = G \sin(\alpha) - 2A mg = G[\sin(\alpha) - 2A]$$

$$F_f = mg[\sin(\alpha) - 2A] = 70 \cdot 9.81[\sin(30) - 2 \cdot 0.1] = 686.7 \cdot 0.3$$

$$F_f = 206.01 \text{ N}$$

7. A material point with mass m is moving along a trajectory given by the Cartesian components: $x(t) = A \cos(kt)$ and $y(t) = B \cos(kt)$. Characterize the force F that produces this type of motion if we know that the force depends only by the material point position. Give some examples.

R: The force components along Ox and Oy axes are:

$$F_x = m \cdot a_x = m \cdot \ddot{x} \Rightarrow F_x = m \cdot \frac{d}{dt} \dot{x} = -mk \cdot \frac{d}{dt} [A \sin(kt)] = -mk^2 A \cos(kt) = -mk^2 x$$

$$F_y = m \cdot a_y = m \cdot \ddot{y} \Rightarrow F_y = m \cdot \frac{d}{dt} \dot{y} = -mk \cdot \frac{d}{dt} [B \sin(kt)] = -mk^2 B \cos(kt) = -mk^2 y$$

The force modulus is:

$$F = \sqrt{F_x^2 + F_y^2} = mk^2 \sqrt{x^2 + y^2} = mk^2 r$$

where \vec{r} is the material point position vector.

The ratio:

$$\frac{F_x}{F} = \frac{-mk^2 x}{mk^2 r} = \frac{-x}{r} = \cos(\hat{x}, F)$$

are the direction cosine of the force F.

$$\frac{F_y}{F} = \frac{-mk^2 y}{mk^2 r} = \frac{-y}{r} = \cos(\hat{y}, F)$$

In the same time are the angles between the position vector and OX and OY axes, respectively. From here we can observe that the force F is anti-parallel with the position vector. Then the force F is pointing to the centre of the reference frame. Such a force is called *attraction central force*.

8. On a body with a mass $m = 2$ kg are acting two forces, $F_1 = 3$ N and $F_2 = 4$ N, which are characterized by the angles $\alpha_1 = 60^\circ$, and $\alpha_2 = 120^\circ$ respectively, with the direction of velocity \vec{v}_0 . Find the body acceleration, \mathbf{a} , velocity, \mathbf{v} and the distance covered into a time $t = 10$ s starting from the beginning of motion (Particular case $v_0 = 20$ m/s).

R: If we are considering a reference frame related to earth then the acceleration components along OX and OY axes are:

$$a_x = \frac{F_1 \cos \alpha_1 + F_2 \cos \alpha_2}{m} = \frac{3 \cos(60) + 4 \cos(120)}{2} = \frac{3 \cdot 0.5 - 4 \cdot 0.5}{2} = -\frac{1}{4} = -0.25 \text{ m/s}^2$$

$$a_y = \frac{F_1 \sin \alpha_1 + F_2 \sin \alpha_2}{m} = \frac{3 \frac{\sqrt{3}}{2} + 4 \frac{\sqrt{3}}{2}}{2} = \frac{7\sqrt{3}}{4} = 3.03 \text{ m/s}^2$$

and the acceleration modulus:

$$a = \sqrt{a_x^2 + a_y^2} = \sqrt{0.25^2 + 3.03^2} = \sqrt{0.0625 + 9.1809} = \sqrt{9.2434} = 3.04 \text{ m/s}^2$$

We observe that the acceleration is constant in time ($a = \text{const}$), the velocity equation can be calculated from:

$$a = \frac{dv}{dt} \Rightarrow dv = a \cdot dt \Rightarrow \int_{v_0}^{v(t)} dv = \int_0^t a \cdot dt' \Rightarrow v(t) - v_0 = at \Rightarrow v(t) = v_0 + at$$

or by components:

$$v_x(t) = v_{0x} + a_x t \quad \text{cu} \quad v_{0x} = v_0$$

$$v_y(t) = v_{0y} + a_y t \quad \text{cu} \quad v_{0y} = 0$$

and from here:

$$v_x(t) = v_0 + a_x t = 20 - 0.25 \cdot 10 = 17.5 \text{ m/s}$$

$$v_y(t) = a_y t = 3.03 \cdot 10 = 30.3 \text{ m/s}$$

and the velocity modulus:

$$v = \sqrt{v_x^2 + v_y^2} = \sqrt{17.5^2 + 30.3^2} = \sqrt{306.25 + 918.09} = \sqrt{1224.34} = 34.99 \text{ m/s}$$

The velocity, \vec{v} at time t makes an angle α cu \vec{v}_0 given by the equation:

$$\text{tg} \alpha = \frac{v_y}{v_x} \Rightarrow \alpha = \text{arctg}\left(\frac{v_y}{v_x}\right) \Rightarrow \alpha = \text{arctg}\left(\frac{30.3}{17.5}\right) = \text{arctg}(1.731) = 59^\circ 59' 28''.$$

In order to calculate the distance we have:

$$v = \frac{ds}{dt} \Rightarrow ds = v \cdot dt \Rightarrow \int_{s_0}^{s(t)} ds = \int_0^t v \cdot dt' \Rightarrow s(t) - s_0 = \int_0^t (v_0 + at) \cdot dt'$$

$$\Rightarrow s(t) = s_0 + v_0 t + \frac{at^2}{2} \quad s_0=0 \Rightarrow s(t) = v_0 t + \frac{at^2}{2} = 20 \cdot 10 + \frac{3.04 \cdot 100}{2} = 200 + 152 = 352 \text{ m}$$

or by components:

$$x(t) = v_0 t + \frac{a_x t^2}{2} = 20 \cdot 10 - \frac{0.25 \cdot 100}{2} = 200 - 12.5 = 187.5 \text{ m}$$

$$y(t) = \frac{a_y t^2}{2} = \frac{3.03 \cdot 100}{2} = 151.5 \text{ m}$$

9. A tractor is traveling with a velocity of $v_0 = 36 \text{ km/h}$. If the radius of the wheel is $R = 0.5 \text{ m}$ find out:

- The parametric motion equations of a point from the external wheel circumference.
- The tangential velocity components and the value of velocity.
- The path distance by a point between two contacts with the road.

$$R: \quad a) \quad v = \omega R \Rightarrow \omega = \frac{v_0}{R} = 20 \frac{\text{rad}}{\text{s}}$$

$$\begin{cases} x = v_0 t + x_w \\ y = 0 \cdot t + y_w \end{cases} \quad \begin{cases} x_w = x_{CW} + x_R \\ y_w = y_{CW} + y_R \end{cases} \quad \begin{cases} x_{CW} = 0 \\ y_{CW} = R + y_R \end{cases} \quad \begin{cases} x_R = -R \sin(\omega t) \\ y_R = -R \cos(\omega t) \end{cases}$$

$$\begin{cases} x_R = v_0 t - R \sin(\omega t) = 10t - 0.5 \sin(20t) \\ y_R = R - R \cos(\omega t) = 0.5 - 0.5 \cos(20t) \end{cases}$$

this is the equations of a cycloid.

$$b) v_x = \frac{dx}{dt} = v_0 - \omega R \cos(\omega t) = v_0 [1 - \cos(\omega t)] = 10[1 - \cos(20t)]$$

$$v_y = \frac{dy}{dt} = \omega R \sin(\omega t) = v_0 \sin(\omega t) = 10 \sin(20t)$$

$$v = \sqrt{v_x^2 + v_y^2} = \sqrt{v_0^2 [1 - \cos(\omega t)]^2 + v_0^2 \sin^2(\omega t)} = v_0 \sqrt{2(1 - \cos(\omega t))} = 2v_0 \sin \frac{\omega t}{2}$$

$$v = 20 \sin 10t$$

$$c) \quad v = \frac{ds}{dt}$$

$$ds = v dt \Rightarrow ds = 2\omega R \sin \frac{\omega t}{2} dt \quad \begin{matrix} \varphi = \omega t \\ d\varphi = \omega dt \end{matrix} \Rightarrow ds = 2R \sin \frac{\varphi}{2} d\varphi$$

$$\int_0^s ds' = \int_0^{2\pi} 2R \sin \frac{\varphi}{2} d\varphi \Rightarrow s = 4R \left(-\cos \frac{\varphi}{2} \right) \Big|_0^{2\pi} = 8R = 4 \text{ m}$$

10. A body with a mass $m = 5 \text{ kg}$ can slide with friction on a horizontal surface if is pushed by a spiral spring, with an elastic constant $k = 200 \text{ N/m}$, and which was compressed at half of his length $l = 20 \text{ cm}$. Find out:

a) the mechanical work of friction force during expansion.

b) how much must is the friction coefficient if in the final position the spring in not stressed.

$$R: \quad a) F_e = -kx$$

$$dW = F \cdot dx \Rightarrow \int_0^W dW' = \int_{-l/2}^0 F \cdot dx \Rightarrow W = \int_{-l/2}^0 -kx \cdot dx = -k \frac{x^2}{2} \Big|_{-l/2}^0 = k \frac{l}{8}$$

$$W = 200 \frac{20^2 \cdot 10^{-4}}{8} = 1 \text{ J}$$

$$b) \Delta E_t = L_f \quad E_f - E_i = L_f \Rightarrow 0 - k \frac{\Delta l^2}{2} = -\mu N \Delta l \Rightarrow \mu = \frac{k \Delta l}{2mg} = -N \Delta l$$

$$\mu = \frac{200 \cdot 0.1}{2 \cdot 5 \cdot 9.81} = 0.204$$

11. A concrete cube with the side of $a = 0.8$ m and a density of 2500 kg/m^3 must be tipped around an edge. Calculate:

- Point of application direction and value of the minimal force needed to turn turn-over;
- The expression of a horizontal force that can turn-over the concrete block if this is applied on superior edge as function of rotation angle.
- The mechanical work spent for turning over the concrete block.

R: a) $\vec{M}_F = \vec{r} \times \vec{F} = r \cdot F \cdot \cos(\overset{\wedge}{rF})$

$$\begin{cases} \cos(\overset{\wedge}{rF}) = 1 \\ r = a\sqrt{2} \\ \mathcal{M}_{F_{\max}} = r \cdot F_{\max} \cdot \cos(\overset{\wedge}{rF}) = a\sqrt{2}F_{\max} \end{cases}$$

$$\mathcal{M}_{F_{\max}} = \mathcal{M}_G \Rightarrow a\sqrt{2}F_{\max} = G \frac{a}{2} \Rightarrow F_{\max} = mg \frac{a}{2a\sqrt{2}} = \frac{\rho V g}{2\sqrt{2}} = \frac{\rho g a^3}{2\sqrt{2}}$$

$$F_{\max} = \frac{2500 \cdot 9.81 \cdot 0.8^3}{2\sqrt{2}} = 4439.5 \text{ N}$$

b)

$$\mathcal{M}_F = aF(\theta) = a \cdot F \cdot \cos(\theta)$$

$$\mathcal{M}_G = G \cdot a \frac{\sqrt{2}}{2} \cdot \cos\left(\frac{\pi}{4} + \theta\right) \quad \mathcal{M}_F = \mathcal{M}_G \Rightarrow aF \cos(\theta) = Ga \frac{\sqrt{2}}{2} \cos\left(\frac{\pi}{4} + \theta\right)$$

$$F = a^3 \rho g \frac{\sqrt{2}}{2 \cos(\theta)} \left[\cos\left(\frac{\pi}{4}\right) \cos(\theta) - \sin\left(\frac{\pi}{4}\right) \sin(\theta) \right] \Rightarrow F = \frac{a^3 \rho g}{2} [1 - \text{tg}(\theta)]$$

$$F(\theta) = \frac{0.8^3 \cdot 2500 \cdot 9.81}{2} [1 - \text{tg}(\theta)] = 6278.4 [1 - \text{tg}(\theta)] \text{ N}$$

c) $W = \mathcal{M}_F \cdot \theta$

$$dW = \mathcal{M}_F \cdot d\theta \Rightarrow \int_0^W dW' = \int_0^{\pi/4} \mathcal{M}_F \cdot d\theta \Rightarrow W = \int_0^{\pi/4} \frac{a^3 \rho g}{2} [1 - \text{tg}(\theta)] \cdot d\theta$$

$$W = \int_0^{\pi/4} a^4 \frac{\sqrt{2}}{2} \rho g \cos\left(\theta + \frac{\pi}{4}\right) \cdot d\theta = a^4 \frac{\sqrt{2}}{2} \rho g \cdot \sin\left(\theta + \frac{\pi}{4}\right) \Big|_0^{\pi/4} = a^4 \frac{\sqrt{2}}{2} \rho g \cdot \left(1 - \frac{\sqrt{2}}{2}\right)$$

$$W = \frac{a^4 \rho g}{2} \cdot (\sqrt{2} - 1) \quad W = \frac{0.8^4 \cdot 2500 \cdot 9.81}{2} \cdot (\sqrt{2} - 1) = 2080.48 \text{ J}$$

12. On an inclined plane with inclination $\alpha = \arcsin(3/5)$ and length $l = 2.1 \text{ m}$ is rolling with no sliding friction an homogeneous sphere of mass $m = 40 \text{ g}$ and radius $R = 10 \text{ mm}$. How much is the transversal velocity, angular velocity and frequency at the base of the plane.

R: $E_{t,A} = E_{t,B}$

$$E_{t,A} = E_{p,A} = mgh = mgl \sin(\alpha)$$

$$E_{t,B} = E_{\text{kin,tr,B}} + E_{\text{kin,rot,B}} \quad E_{\text{kin,tr,B}} = \frac{mv^2}{2} \quad E_{\text{kin,rot,B}} = \frac{I\omega^2}{2}$$

$$I = \frac{2}{5}mR^2 \quad v = \omega R \Rightarrow \omega = \frac{v}{R}$$

$$E_{t,B} = \frac{mv^2}{2} + \frac{I\omega^2}{2} = \frac{mv^2}{2} + \frac{2}{5}mR^2 \frac{v^2}{2R^2} = \frac{mv^2}{2} + \frac{2}{5} \frac{mv^2}{2} = \frac{7}{5} \frac{mv^2}{2}$$

$$mgl \sin(\alpha) = \frac{7}{5} \frac{mv^2}{2} \Rightarrow v = \sqrt{\frac{10}{7} gl \sin(\alpha)} \Rightarrow v = \sqrt{\frac{10}{7} \cdot 9.81 \cdot 2.1 \cdot \frac{3}{5}} = 4.20 \frac{\text{m}}{\text{s}}$$

$$\omega = \frac{v}{R} = \frac{4.2}{0.01} = 420.2 \frac{\text{rad}}{\text{s}}$$

$$\nu = \frac{\omega}{2\pi} = \frac{420.2}{2\pi} = 66.88 \text{ Hz}$$

13. Demonstrate that after a perfect elastic collision of two hockey pucks of the same mass, initially the first one being at rest, the angle between the directions of pucks is 90° . How much are the velocities and scatter angle θ_2 if the initial velocity of projectile puck is $v = 40 \text{ km/h}$ and $\theta_1 = 60^\circ$?

R:

$$\begin{cases} \vec{E}_{c,i} = \vec{E}_{c,f} \\ \vec{p}_i = \vec{p}_f \end{cases} \Rightarrow \begin{cases} mv^2 = mv_1^2 + mv_2^2 \\ \vec{p} = \vec{p}_1 + \vec{p}_2 \end{cases} \Rightarrow \begin{cases} m^2v^2 = m^2v_1^2 + m^2v_2^2 \\ \vec{p} = \vec{p}_1 + \vec{p}_2 \end{cases}$$

$$\begin{cases} \vec{p}^2 = \vec{p}_1^2 + \vec{p}_2^2 \\ \vec{p} = \vec{p}_1 + \vec{p}_2 \end{cases} \Rightarrow (\vec{p}_1 + \vec{p}_2)^2 = \vec{p}_1^2 + \vec{p}_2^2 + 2\vec{p}_1\vec{p}_2 = \vec{p}_1^2 + \vec{p}_2^2 \Rightarrow 2\vec{p}_1\vec{p}_2 \cos(\theta_1 + \theta_2) = 0$$

$$\cos(\theta_1 + \theta_2) = 0 \Rightarrow \theta_1 + \theta_2 = 90^\circ \Rightarrow \vec{p}_1 \perp \vec{p}_2$$

$$\theta_2 = 90^\circ - \theta_1 = 90^\circ - 60^\circ = 30^\circ$$

$$\cos(\theta_1) = \frac{mv_1}{mv} = \frac{v_1}{v} \Rightarrow v_1 = v \cos(\theta_1) = 40 \cdot \frac{1}{2} = 20 \frac{\text{m}}{\text{s}}$$

$$\cos(\theta_2) = \frac{mv_2}{mv} = \frac{v_2}{v} \Rightarrow v_2 = v \cos(\theta_2) = 40 \cdot \frac{\sqrt{3}}{2} = 34.64 \frac{\text{m}}{\text{s}}$$

14. On the deflection plates of a cathodic oscilloscope with sensibility of 2 cm/V on both axes Ox and Oy it is applied simultaneously the electric voltage $U_x = 2 \cos(100t)$ and $U_y = 4 \sin^2(50t)$. Calculate:

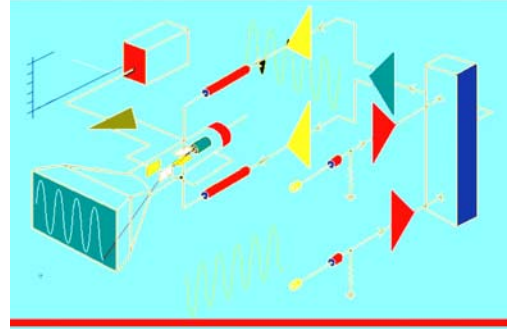

- i. The spot equations of motion on Ox and Oy axes.
- ii. Equation of the trajectory.

R: a) $S_x = \frac{x}{U_x} \Rightarrow x = S_x U_x = 2 \frac{\text{cm}}{\text{V}} 2V \cos(100t) \Rightarrow x = 4 \cos(100t) (\text{cm})$

$$S_y = \frac{y}{U_y} \Rightarrow y = S_y U_y = 2 \frac{\text{cm}}{\text{V}} 4V \sin^2(50t) \Rightarrow y = 8 \sin^2(50t) (\text{cm})$$

b) $\begin{cases} x = 4 \cos(100t) \\ x = 8 \sin^2(50t) \end{cases} \Rightarrow \begin{cases} \frac{x}{4} = \cos(100t) \\ y = 8 \frac{1 - \cos(100t)}{2} \end{cases} \Rightarrow \begin{cases} \frac{x}{4} = \cos(100t) \\ y = 4[1 - \cos(100t)] \end{cases}$

$$y = 4 \left[1 - \frac{x}{4} \right] = 4 - x \Rightarrow x + y = 4$$

15. A material point execute a motion described by the equation: $x(t) = 2 \sin^2\left(3\pi t + \frac{\pi}{2}\right)$. Show that this is a harmonic oscillatory motion. Find the amplitude and period of motion, the velocity and acceleration of the material point.

R: $\begin{cases} x(t) = 2 \sin^2\left(3\pi t + \frac{\pi}{2}\right) \\ \sin^2(\alpha) = \frac{1 - \cos(2\alpha)}{2} \end{cases} \Rightarrow x(t) = 2 \frac{1 - \cos(6\pi t + \pi)}{2} = 1 + \cos(6\pi t) = 1 + \sin\left(6\pi t + \frac{\pi}{2}\right)$

$$\begin{cases} x(t) = x' + A \sin(\omega t + \varphi_0) \\ x(t) = 1 + \sin\left(6\pi t + \frac{\pi}{2}\right) \end{cases} \Rightarrow \begin{cases} x' = 1 & A = 1 \\ \omega = 6\pi & \Rightarrow \omega = \frac{2\pi}{T} = 6\pi \Rightarrow T = \frac{1}{3} = 0.33 \text{ s} \\ \varphi_0 = \pi/2 \end{cases}$$

$$v = \frac{dx}{dt} = \frac{d}{dt} \{x' + A \sin(\omega t + \varphi_0)\} = A\omega \cos(\omega t + \varphi_0) = 6\pi \cos\left(6\pi t + \frac{\pi}{2}\right)$$

$$a = \frac{dv}{dt} = -36\pi^2 \sin\left(6\pi t + \frac{\pi}{2}\right)$$

16. A material point with the mass $m = 10 \text{ g}$ is oscillating under the law:

$$x(t) = 10 \cos^2\left(\frac{\pi}{12}t - \frac{\pi}{4}\right) - 5. \text{ Calculate:}$$

- The time t_1 necessary to reach the maximum velocity, and the time t_2 necessary to reach the maximum acceleration;
- The maximum value of the elastic force that act on the material point;
- Expression of kinetic, potential and total energy.

R:

$$a) \begin{cases} x(t) = 10 \cos^2\left(\frac{\pi}{12}t - \frac{\pi}{4}\right) - 5 \\ \cos^2(\alpha) = \frac{1 + \cos(2\alpha)}{2} \end{cases} \Rightarrow x(t) = 10 \frac{1 + \cos\left(\frac{\pi}{6}t - \frac{\pi}{2}\right)}{2} - 5 = 5 \sin\left(\frac{\pi}{6}t\right)$$

$$v = \frac{dx}{dt} = 5 \frac{\pi}{6} \cos\left(\frac{\pi}{6}t\right) \Rightarrow \begin{cases} v_{\max} = 5 \frac{\pi}{6} \\ \cos\left(\frac{\pi}{6}t_1\right) = \pm 1 \end{cases} \Rightarrow \frac{\pi}{6}t_1 = n\pi \Rightarrow t_1 = 6n \text{ s}$$

$$a = \frac{dv}{dt} = -5 \frac{\pi^2}{36} \sin\left(\frac{\pi}{6}t\right) \Rightarrow \begin{cases} a_{\max} = 5 \frac{\pi^2}{36} \\ \sin\left(\frac{\pi}{6}t_2\right) = \pm 1 \end{cases} \Rightarrow \frac{\pi}{6}t_2 = (2n+1)\frac{\pi}{2} \Rightarrow t_2 = 3(2n+1) \text{ s}$$

$$b) F_e = -kx = -kA \sin(\omega t + \varphi_0) = F_{\max} \sin(\omega t + \varphi_0)$$

$$F_{\max} = kA = m\omega^2 A = 10 \cdot 10^{-3} \cdot \frac{\pi^2}{36} \cdot 5 \cdot 10^{-2} = 1.37 \cdot 10^{-4} \text{ N}$$

$$c) E_c = \frac{mv^2}{2} = \frac{mA^2\omega^2 \cos^2(\omega t)}{2} = \frac{10 \cdot 25 \cdot 10^{-4} \cdot \frac{\pi^2}{36}}{2} \cos^2\left(\frac{\pi}{6}t\right) = 3.43 \cdot 10^{-6} \cos^2\left(\frac{\pi}{6}t\right) \text{ J}$$

$$E_p = \frac{kx^2}{2} = \frac{mA^2\omega^2 \sin^2(\omega t)}{2} = \frac{10 \cdot \frac{\pi^2}{36} \cdot 25 \cdot 10^{-4}}{2} \sin^2\left(\frac{\pi}{6}t\right) = 3.43 \cdot 10^{-6} \sin^2\left(\frac{\pi}{6}t\right) \text{ J}$$

$$E_t = \frac{mv^2}{2} + \frac{kx^2}{2} = 3.43 \cdot 10^{-6} \text{ J}$$

17. A harmonic oscillator which oscillates with the amplitude, A of 8 mm is after $\tau = 0.01$ s from the beginning of motion (from equilibrium position) at the distance 4 mm measured from equilibrium position. Calculate:

- oscillatory pulsation;
- oscillatory period;
- oscillatory frequency;
- velocity of oscillation in the given position;
- acceleration of oscillation in the given position.

R: a) $y(t) = A \sin(\omega t + \varphi_0)$

$$y(0) = 0 = A \sin(\omega \cdot 0 + \varphi_0) \Rightarrow \sin(\varphi_0) = 0 \Rightarrow \varphi_0 = 0$$

$$y(\tau) = 4 = \frac{A}{2} = A \sin(\omega \tau) \Rightarrow \sin(\omega \tau) = \frac{1}{2} \Rightarrow \omega \tau = \frac{\pi}{6} \Rightarrow \omega = \frac{\pi}{6\tau} = \frac{\pi}{6 \cdot 0.01} \Rightarrow \omega = \frac{50}{3} \pi$$

$$\text{b) } \omega = \frac{2\pi}{T} \Rightarrow T = \frac{2\pi}{\omega} = \frac{2\pi}{\frac{50}{3}\pi} \Rightarrow T = 0.12 \text{ s}$$

$$\text{c) } \nu = \frac{1}{T} = \frac{1}{0.12} \Rightarrow \nu = 8.33 \text{ Hz}$$

$$\text{d) } v = \frac{dy}{dt} = \omega A \cos(\omega t) \Rightarrow v(\tau) = \frac{50}{3} \pi \cdot 8 \cdot 10^{-3} \cos\left(\frac{50}{3} \pi \cdot 0.01\right) = 0.419 \cos\left(\frac{\pi}{6}\right) \Rightarrow v(\tau) = 0.36 \text{ m/s}$$

$$\text{e) } a = \frac{dv}{dt} = -\omega^2 A \sin(\omega t) \Rightarrow a(\tau) = \frac{2500}{9} \pi^2 \cdot 8 \cdot 10^{-3} \sin\left(\frac{50}{3} \pi \cdot 0.01\right) = \Rightarrow a(\tau) = 10.97 \frac{\text{m}}{\text{s}^2}$$

18. The sonic boom created by an airplane it is heard in the moment in which the direction observer-airplane makes an angle $\alpha = 60^\circ$ with the vertical. How much is the airplane speed? ($v_s = 340$ m/s)

R: $\theta = 90 - \alpha$

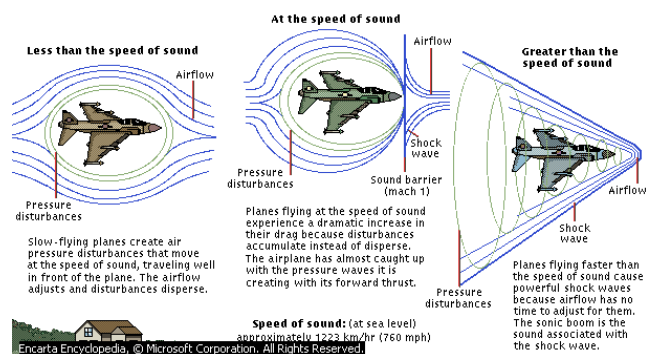

$$\sin \theta = \frac{A_0}{AA'} = \frac{v_s \cdot t}{v_a \cdot t} \Rightarrow v_a = \frac{v_s}{\sin \theta} = \frac{v_s}{\cos \alpha} = \frac{340}{\frac{1}{2}} = 2 \cdot 340 = 680 \frac{\text{m}}{\text{s}} = 2 \text{ Mach}$$

19. How much is the fundamental frequency of vibration of a copper wire ($\rho = 8.9$ kg/dm³) with section of 2 mm² and the length of 1 m when is stress with a force of 17.8 daN.

$$R: \lambda = vT \Rightarrow \lambda = \frac{v}{\nu} \Rightarrow \nu = \frac{v}{\lambda}$$

$$\begin{cases} v = \sqrt{\frac{T}{\mu}} \\ \mu = \frac{m}{l} = \frac{\rho V}{l} = \frac{\rho S l}{l} = \rho S \end{cases} \Rightarrow v = \sqrt{\frac{T}{\rho S}} ; \lambda = 2l$$

$$\nu = \frac{1}{2l} \sqrt{\frac{T}{\rho S}} = \frac{1}{2 \cdot 1} \sqrt{\frac{17.8 \cdot 10}{8900 \cdot 2 \cdot 10^{-6}}} = \frac{100}{2} = 50 \text{ Hz}$$

20. Calculate the wavelength value of a sound of 440 Hz in air ($v_a = 340 \text{ m/s}$) and into a tram line ($v_t = 5000 \text{ m/s}$). Calculate the steel Young modulus if the density is ($\rho_t = 8000 \text{ kg/m}^3$).

$$R: \lambda_a = \frac{v_a}{\nu} = \frac{340}{440} = 0.773 \text{ m} = 77.3 \text{ cm}$$

$$\lambda_t = \frac{v_t}{\nu} = \frac{5000}{440} = 11.36 \text{ m}$$

$$v_t = \sqrt{\frac{E}{\rho}} \Rightarrow E = \rho v_t^2 = 8 \cdot 10^3 \cdot (5 \cdot 10^3)^2 = 2 \cdot 10^{11} \frac{\text{N}}{\text{m}^2}$$

21. In the liquid Helium (below 4.2 K) the sound velocity is 220 m/s. If we know the He density $\rho = 0.15 \text{ g/cm}^3$ find the compressibility modulus. Compare this result with the water compressibility modulus if we know that the sound velocity is 1460 m/s.

$$R: v_{\text{He}} = \sqrt{\frac{\chi_{\text{He}}}{\rho}} \Rightarrow \chi_{\text{He}} = \rho v_{\text{He}}^2 = 150 \cdot 220^2 = 7.26 \cdot 10^6 \frac{\text{N}}{\text{m}^2}$$

$$\chi_w = \rho v_w^2 = 1000 \cdot 1460^2 = 2.1316 \cdot 10^9 \frac{\text{N}}{\text{m}^2}$$

$$\frac{\chi_w}{\chi_{\text{He}}} = \frac{2.1316 \cdot 10^9}{7.26 \cdot 10^6} = 293.6$$

22. By a copper wire with the length $l = 160 \text{ cm}$ and diameter $\phi = 1 \text{ mm}$ is suspended a body with mass 10 kg. If the copper wire elongation is 2.56 mm find out:

a. The stress, $\sigma = \frac{F}{S}$, strain, $\varepsilon = \frac{\Delta l}{l}$ and elastic constant, k ;

b. The Young modulus, E ;

c. How much is the inter-atomic distance if in the unstressed material is $R_0 = 2.56 \text{ \AA}$;

R: a) $\sigma = \frac{F}{S} = \frac{mg}{\pi r^2} = \frac{4mg}{\pi d^2} = \frac{4 \cdot 10 \cdot 9.81}{\pi \cdot 10^{-6}} = 1.25 \cdot 10^8 \frac{\text{N}}{\text{m}^2}$

$$\varepsilon = \frac{\Delta l}{l} = \frac{2.56 \cdot 10^{-3}}{1.6} = 1.6 \cdot 10^{-3} = 0.16\%$$

$$F = -F_e = k\Delta l = mg \Rightarrow k = \frac{mg}{\Delta l} = \frac{10 \cdot 9.81}{2.56 \cdot 10^{-3}} = 3.83 \cdot 10^4 \frac{\text{N}}{\text{m}}$$

$$\text{b) } \frac{F}{S} = E \frac{\Delta l}{l} \Rightarrow \sigma = E\varepsilon \Rightarrow E = \frac{\sigma}{\varepsilon} = \frac{1.25 \cdot 10^8}{1.6 \cdot 10^{-3}} = 7.8 \cdot 10^{10} \frac{\text{N}}{\text{m}^2}$$

$$\text{c) } \frac{\Delta R}{R_0} = \frac{\Delta l}{l} \Rightarrow \Delta R = \frac{\Delta l}{l} R_0 = \varepsilon R_0 = 1.6 \cdot 10^{-3} \cdot 2.56 \cdot 10^{-10} = 4.096 \cdot 10^{-13} \text{ m.}$$

23. In front of a microphone a sound has the pressure of 0.441 Pa (N/m²). How much we have to amplify the sound in order to reach the pain threshold, $I_{\text{pain}} = 10^2 \text{ W/m}^2$? We know the air acoustic impedance $Z_a = \rho c = 441 \text{ kg/m}^2\text{s}$. How much is the pressure and the sound level?

R: $N_m + N_A = N_L \Rightarrow N_A = N_L - N_m$

$$N_m = 10 \lg \left(\frac{I_m}{I_0} \right) \quad N_L = 10 \lg \left(\frac{I_L}{I_0} \right)$$

$$N_A = N_L - N_m \Rightarrow N_A = 10 \lg \left(\frac{I_L}{I_0} \right) - 10 \lg \left(\frac{I_m}{I_0} \right) = 10 \lg \left(\frac{I_L}{I_m} \right)$$

$$\begin{cases} I_L = I_{\text{pain}} \\ I_m = \frac{p^2}{\rho c} = \frac{p^2}{Z_a} = \frac{0.441^2}{441} = 4.41 \times 10^{-4} \frac{\text{W}}{\text{m}^2} \end{cases}$$

$$N_A = 10 \lg \left(\frac{I_L}{I_m} \right) = 10 \lg \left(\frac{10^2}{4.41 \cdot 10^{-4}} \right) = 60 \lg \left(\frac{1}{4.41} \right)$$

$$N_A = 53.5 \text{ dB}$$

24. Find the relation between the intensity of wave into an absorbed media as a function of depth of penetration and absorption coefficient.

R:

$$dI = -\alpha I dx \Rightarrow \frac{dI}{I} = -\alpha dx \Rightarrow \int_{I_0}^{I(x)} \frac{dI}{I} = \int_0^x -\alpha dx \Rightarrow \ln \left(\frac{I(x)}{I_0} \right) = -\alpha x \Rightarrow I(x) = I_0 e^{-\alpha x}$$

25. Hydrogen atom is constituted from a proton and an electron with equal electrical charges but opposite sign, and absolute value $e = 1.6 \times 10^{-19} \text{ C}$. In the fundamental state, the radius of electron first orbit around proton is $r_0 = 0.53 \times 10^{-10} \text{ m}$. Calculate the attraction force between proton and electron.

R:

$$F_C = -\frac{1}{4\pi\epsilon_0} \frac{e^2}{r_0^2} = -9 \cdot 10^9 \frac{(1.6 \cdot 10^{-19})^2}{(5.3 \cdot 10^{-11})^2} = -9 \cdot \frac{1.6^2}{5.3^2} \cdot 10^{9-38+22} = -0.82 \cdot 10^{-7}$$

$$F_C = -8.2 \cdot 10^{-8} \text{ N}$$

26. What is the value of equal electrical charges, with which two identical balls, having the same mass 1 kg, must be charged, if these are situated in air at 1 mm distance, and the Coulombian force that acts on each ball is equal in value with the ball weight into a place in which the gravitational acceleration is $g = 9.8 \text{ m/s}^2$.

R:

$$F_C = -k_e \frac{e^2}{r_{pp}^2} \quad F_G = -k_g \frac{m_p^2}{r_{pp}^2}$$

$$\frac{F_C}{F_G} = -k_e \frac{e^2}{r_{pp}^2} / -k_g \frac{m_p^2}{r_{pp}^2} = \frac{k_e}{k_g} \frac{e^2}{m_p^2} = \frac{9 \cdot 10^9}{6.67 \cdot 10^{-11}} \frac{(1.6 \cdot 10^{-19})^2}{(1.67 \cdot 10^{-27})^2} = \frac{9 \cdot 1.6^2}{6.67 \cdot 1.67^2} \cdot 10^{9-38+11+54}$$

$$\frac{F_C}{F_G} = 1.238 \cdot 10^{36}$$

27. Two small identical spheres placed in void, having the same mass $m = 0.1 \text{ kg}$ are suspended from a single point with the help of two isolated wires, not extensible, of neglected mass and with the same length $l = 20 \text{ cm}$. What is the value of the equal charges with which the two spheres must be charged in such way that the angle between the wires should be $2\alpha = 90^\circ$? The gravitational acceleration is considered $g = 9.8 \text{ m/s}^2$. ($\sin 45 = 0.707$; $\tan 45 = 1$).

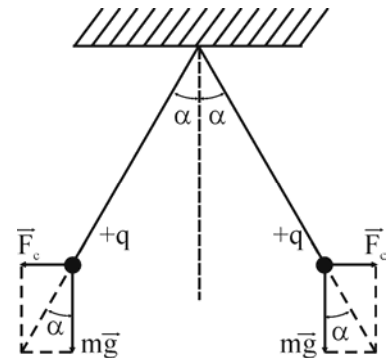

R: $F_C = -k_e \frac{q^2}{d^2}$

$$G = mg \quad d = 2l \sin \alpha$$

$$\tan \frac{\alpha}{2} = \frac{F_C}{G} = \frac{k_e \frac{q^2}{d^2}}{mg} \Rightarrow q = d \sqrt{\frac{m \cdot g \cdot \tan \frac{\alpha}{2}}{k_e}} = 2l \cdot \sin \frac{\alpha}{2} \sqrt{\frac{m \cdot g \cdot \tan \frac{\alpha}{2}}{k_e}}$$

$$q = 2 \cdot 0.2 \cdot \sin(45^\circ) \sqrt{\frac{0.1 \cdot 9.8 \cdot \tan(45^\circ)}{9 \cdot 10^9}} \quad q = 0.4 \cdot 0.707 \sqrt{\frac{0.98 \cdot 1}{90}} \cdot 10^{-4} = 2.95 \cdot 10^{-6}$$

$$q = 2.95 \cdot 10^{-6} \text{ C}$$

28. Calculate the dependence of electrical field intensity and electrical potential on the center of a sphere having the electrical charge uniform distributed in the entire volume. The total charge is denoted by Q and the sphere radius by R .

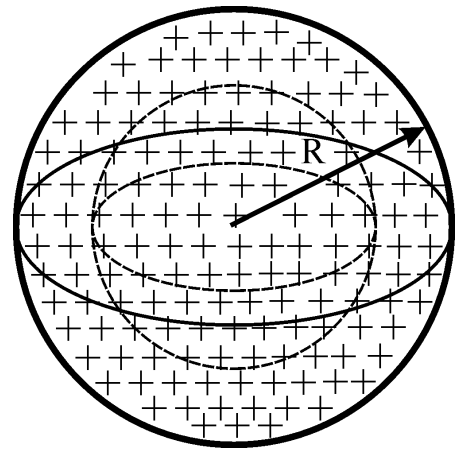

R: a) $r < R$;

$$\oint_{\Sigma} \vec{E} \cdot d\vec{s} = \frac{Q_i}{\epsilon_0} \Rightarrow \oint_{\Sigma} \vec{E} \cdot \vec{n} \cdot ds = \frac{Q_i}{\epsilon_0}$$

$$\Rightarrow E \cdot \oint_{\Sigma} d\vec{s} = \frac{Q_i}{\epsilon_0} \Rightarrow E \cdot 4\pi \cdot r^2 = \frac{Q_i}{\epsilon_0}$$

$$\rho = \frac{Q}{V} = \frac{Q}{\frac{4\pi R^3}{3}} = \frac{Q_i}{\frac{4\pi r^3}{3}} \Rightarrow Q_i = \frac{r^3}{R^3} Q$$

$$\vec{E} \cdot 4\pi \cdot r^2 = \frac{1}{\epsilon_0} \frac{r^3}{R^3} Q \Rightarrow \vec{E} = \frac{Q}{4\pi \cdot \epsilon_0} \frac{r}{R^3}$$

$$\vec{E} = -\nabla V = -\frac{dV}{dr} \quad dV = -E \cdot dr \Rightarrow \int_{V(0)}^{V(r)} dV = -\int_0^r E \cdot dr' \Rightarrow V(r) - V(0) = -\int_0^r \frac{Q}{4\pi \cdot \epsilon_0} \frac{r'}{R^3} \cdot dr'$$

$$V(r) = -\frac{Q}{4\pi \cdot \epsilon_0} \frac{1}{R^3} \int_0^r r' \cdot dr' \quad V(r) = -\frac{Q}{4\pi \cdot \epsilon_0} \frac{1}{R^3} \frac{r^2}{2} \quad V(r) = -\frac{Q}{8\pi \cdot \epsilon_0} \frac{r^2}{R^3}$$

b) $r > R$;

$$\oint_{\Sigma} \vec{E} \cdot d\vec{s} = \frac{Q_i}{\epsilon_0} \Rightarrow \oint_{\Sigma} \vec{E} \cdot \vec{n} \cdot ds = \frac{Q_i}{\epsilon_0} \Rightarrow \vec{E} \cdot \oint_{\Sigma} d\vec{s} = \frac{Q}{\epsilon_0} \Rightarrow \vec{E} \cdot 4\pi \cdot r^2 = \frac{Q}{\epsilon_0} \quad \vec{E} = \frac{Q}{4\pi \epsilon_0 r^2}$$

$$\vec{E} = -\nabla V = -\frac{dV}{dr} \Rightarrow dV = -E \cdot dr \Rightarrow \int_{V(R)}^{V(r)} dV = -\int_R^r E \cdot dr' \Rightarrow$$

$$V(r) - V(R) = -\int_R^r \frac{Q}{4\pi \epsilon_0 r'^2} \cdot dr' \Rightarrow V(r) - V(R) = -\frac{Q}{4\pi \epsilon_0 r^2} \int_R^r \frac{1}{r'^2} \cdot dr'$$

$$V(r) - V(R) = \frac{Q}{4\pi \epsilon_0 r^2} \int_R^r d\left(\frac{1}{r'}\right) \Rightarrow V(r) - V(R) = \frac{Q}{4\pi \epsilon_0 r} - \frac{Q}{4\pi \epsilon_0 R}$$

$$V(r) = \frac{Q}{4\pi \epsilon_0 r}$$

29. Calculate the electric field intensity at a distance a from a rod, uniformly charged with a total charge Q .

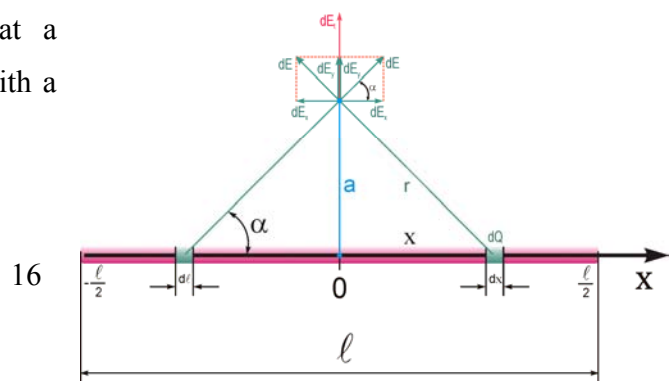

$$R: \quad dE = \frac{1}{4\pi\epsilon_0} \frac{dQ}{r^2} \quad dE_t = 2dE_y = 2dE \cdot \sin\alpha \quad \sin\alpha = \frac{a}{r}$$

$$\lambda = \frac{Q}{l} = \frac{dQ}{dl} \quad dQ = \lambda dl = \lambda dx \quad r^2 = a^2 + x^2$$

$$\int_0^{E_t} dE_t = \int_0^{l/2} 2 \sin\alpha \frac{1}{4\pi\epsilon_0} \frac{\lambda dx}{r^2} \Rightarrow E_t = 2 \frac{\lambda \cdot a}{4\pi\epsilon_0} \int_0^{l/2} \frac{dx}{r^3} = 2 \frac{\lambda \cdot a}{4\pi\epsilon_0} \int_0^{l/2} \frac{dx}{(a^2 + x^2)^{3/2}}$$

$$d\left(x(a^2 + x^2)^{-1/2}\right) = dx \cdot (a^2 + x^2)^{-1/2} + x \left(-\frac{1}{2}\right) (a^2 + x^2)^{-3/2} 2x \cdot dx = \frac{1}{(a^2 + x^2)^{1/2}} \left[1 - \frac{x^2}{(a^2 + x^2)}\right] dx$$

$$= \frac{a^2 + x^2 - x^2}{(a^2 + x^2)^{3/2}} dx = \frac{a^2}{(a^2 + x^2)^{3/2}} dx$$

$$E_t = 2 \frac{1}{4\pi\epsilon_0} \frac{\lambda}{a} \int_0^{l/2} \frac{a^2 \cdot dx}{(a^2 + x^2)^{3/2}} = 2 \frac{1}{4\pi\epsilon_0} \frac{\lambda}{a} \int_0^{l/2} d\left(\frac{x}{\sqrt{a^2 + x^2}}\right) = 2 \frac{1}{4\pi\epsilon_0} \frac{\lambda}{a} \left(\frac{x}{\sqrt{a^2 + x^2}}\right) \Bigg|_0^{l/2}$$

$$= 2 \frac{1}{4\pi\epsilon_0} \frac{\lambda}{a} \frac{1/2}{\sqrt{a^2 + \frac{l^2}{4}}} = \frac{1}{4\pi\epsilon_0} \frac{Q}{a \cdot l} \frac{1}{\sqrt{a^2 + \frac{l^2}{4}}}$$

$$E_t = \frac{1}{4\pi\epsilon_0} \frac{Q}{2a\sqrt{4a^2 + l^2}}$$

30. Let's consider a coaxial cable constituted from two conductors having the radius a and b , with $a < b$. Use the Gauss theorem to determine the dependence of electrical field intensity and electric potential from the coaxial cable axes. Calculate the coaxial cable capacity. The cable length is labeled by l is charged with an electrical charge q .

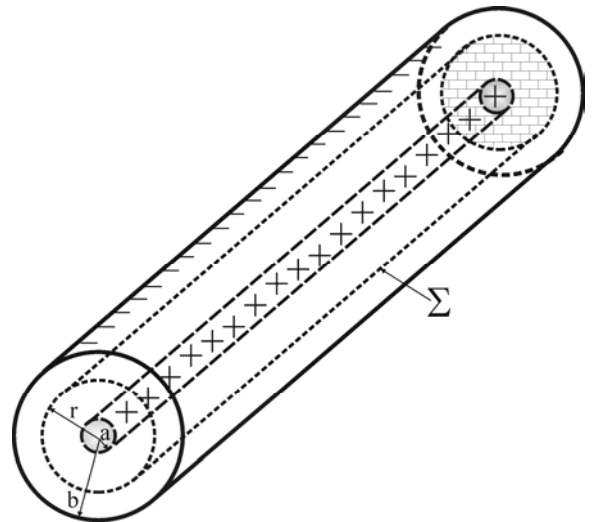

R: a) $r < a$;

$$\oint_{\Sigma} \vec{E} \cdot d\vec{s} = \frac{Q_i}{\epsilon_0} \Rightarrow \oint_{\Sigma} \vec{E} \cdot d\vec{s} = \frac{0}{\epsilon_0} \Rightarrow \vec{E} = 0$$

$$\vec{E} = -\nabla V = -\frac{dV}{dr} \Rightarrow dV = -E \cdot dr \Rightarrow dV = 0 \Rightarrow V = \text{const}$$

b) $r > b$;

$$\oint_{\Sigma} \vec{E} \cdot d\vec{s} = \frac{Q_i}{\epsilon_0} \Rightarrow \oint_{\Sigma} \vec{E} \cdot d\vec{s} = \frac{0}{\epsilon_0} \Rightarrow \vec{E} = 0$$

$$\vec{E} = -\nabla V = -\frac{dV}{dr} \Rightarrow dV = -E \cdot dr \Rightarrow dV = 0 \Rightarrow V = \text{const}$$

c) $a < r < b$;

$$\oint_{\Sigma} \vec{E} \cdot d\vec{s} = \frac{Q_i}{\epsilon_0} \Rightarrow \oint_{\Sigma} \vec{E} \cdot \vec{n} \cdot ds = \frac{Q_i}{\epsilon_0} \Rightarrow \oint_{\Sigma_1} \vec{E} \cdot \vec{n} \cdot ds + \oint_{\Sigma_2} \vec{E} \cdot \vec{n} \cdot ds + \oint_{\Sigma_3} \vec{E} \cdot \vec{n} \cdot ds = \frac{Q_i}{\epsilon_0}$$

$$\Rightarrow E \cdot \oint_{\Sigma} d\vec{s} = \frac{Q_i}{\epsilon_0} \Rightarrow E \cdot 2\pi r \cdot l = \frac{Q_i}{\epsilon_0}$$

$$\lambda = \frac{Q}{L} = \frac{Q_i}{l} \Rightarrow E \cdot 2\pi r \cdot l = \frac{\lambda \cdot l}{\epsilon_0} \Rightarrow E = \frac{\lambda}{2\pi r \epsilon_0} \Rightarrow E = \frac{Q}{2\pi l \epsilon_0 r}$$

$$\vec{E} = -\nabla V = -\frac{dV}{dr} \Rightarrow dV = -E \cdot dr \Rightarrow \int_{V(a)}^{V(b)} dV = -\int_a^b \frac{Q}{2\pi l \epsilon_0 r} \cdot dr' \Rightarrow$$

$$V(a) - V(b) = \frac{Q}{2\pi l \epsilon_0} \int_a^b \frac{1}{r'} \cdot dr' \quad V(a) - V(b) = U = \frac{Q}{2\pi l \epsilon_0} \ln\left(\frac{b}{a}\right)$$

$$V(r) = \frac{Q}{2\pi l \epsilon_0} \ln(r) \quad C = \frac{Q}{U} = \frac{2\pi l \epsilon_0}{\ln\left(\frac{b}{a}\right)}$$

31. Use the Gauss theorem to calculate the expression of a plane capacitor capacity.

R:

$$\oint_{\Sigma} \vec{E} \cdot d\vec{s} = \frac{Q_i}{\epsilon_0} \Rightarrow \oint_{\Sigma} \vec{E} \cdot \vec{n} \cdot ds = \frac{Q_i}{\epsilon_0}$$

$$\Rightarrow \oint_{S_1} \vec{E} \cdot \vec{n} \cdot ds + \oint_{S_2} \vec{E} \cdot \vec{n} \cdot ds + \oint_{S_3} \vec{E} \cdot \vec{n} \cdot ds = \frac{Q_i}{\epsilon_0}$$

$$\Rightarrow E \cdot \oint_{S_1} ds + E \cdot \oint_{S_2} ds + 0 = \frac{Q_i}{\epsilon_0} \Rightarrow 2E \cdot \oint_{S_1} ds = \frac{Q_i}{\epsilon_0}$$

$$\Rightarrow 2E \cdot S_1 = \frac{Q_i}{\epsilon_0}; \quad \sigma = \frac{Q}{S} = \frac{Q_i}{S_1}; \quad Q_i = \sigma \cdot S_1$$

$$\Rightarrow 2E \cdot S_1 = \frac{\sigma \cdot S_1}{\epsilon_0} \Rightarrow E = \frac{\sigma}{2\epsilon_0} \quad E_C = 2E = \frac{\sigma}{\epsilon_0}$$

$$\vec{E} = -\nabla V = -\frac{dV}{dx}$$

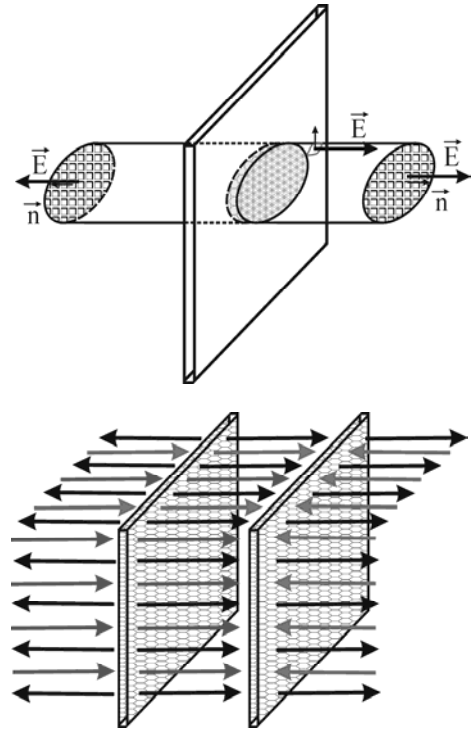

$$dV = -E \cdot dx \Rightarrow \int_{V(a)}^{V(b)} dV = -E \cdot \int_a^b dr' \Rightarrow V(a) - V(b) = E(b - a)$$

$$V(a) - V(b) = U = E \cdot d \quad U = \frac{\sigma}{\epsilon_0} \cdot d = \frac{Q}{\epsilon_0 \cdot S} \cdot d \quad C = \frac{Q}{U} = \frac{\epsilon_0 \cdot S}{d}$$

32. Apply the Ampere's law to Calculate the magnetic induction a) at a distance r from an infinitely long conductor b) and inside of an infinitely long solenoid (coil).

$$\text{R: a) } \oint_c \vec{B} \cdot d\vec{l} = \mu_0 \cdot I \Rightarrow B \cdot \oint_c dl = \mu_0 \cdot I \Rightarrow B \cdot 2\pi r = \mu_0 \cdot I \Rightarrow B = \frac{\mu_0 \cdot I}{2\pi r}$$

$$\text{b) } \oint_c \vec{B} \cdot d\vec{l} = \mu_0 \cdot I_t = \int_a^b \vec{B} \cdot d\vec{l} + \int_b^c \vec{B} \cdot d\vec{l} + \int_c^d \vec{B} \cdot d\vec{l} + \int_d^a \vec{B} \cdot d\vec{l} = \mu_0 \cdot N \cdot I \Rightarrow$$

$$\int_a^b \vec{B} \cdot d\vec{l} + 0 + 0 + 0 = \mu_0 \cdot N \cdot I \Rightarrow B \cdot \int_a^b dl = \mu_0 \cdot N \cdot I \Rightarrow$$

$$B \cdot l = \mu_0 \cdot N \cdot I \Rightarrow B = \frac{\mu_0 \cdot N \cdot I}{l} = \mu_0 \cdot n \cdot I$$

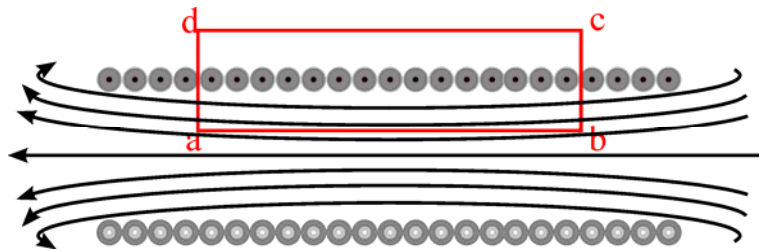

33. Two electric currents $I_1 = 5 \text{ A}$ and $I_2 = 10 \text{ A}$ of the same sense are flowing through two parallel conductors, situated at a distance $d_1 = 20 \text{ cm}$ one from each other. Calculate:

a) The force per unit length with which the two conductors are mutually attracting;

b) Calculate the mechanical work per unitary length spend to move the conductors at distance $d_2 = 30 \text{ cm}$ one from each other. ($\mu_0 = 4\pi \times 10^{-7} \text{ H/m}$).

$$\text{R: a) } \left. \begin{array}{l} F_{12} = B_1 \cdot I_2 \cdot L \\ B_1 = \frac{\mu_0 \cdot I_1}{2\pi \cdot d_1} \end{array} \right\} \Rightarrow F_{12} = \frac{\mu_0 \cdot I_1}{2\pi \cdot d_1} \cdot I_2 \cdot L \Rightarrow \frac{F_{12}}{L} = \frac{\mu_0 \cdot I_1 \cdot I_2}{2\pi \cdot d_1} \Rightarrow$$

$$\frac{F_{12}}{L} = \frac{4\pi \cdot 10^{-7} \cdot 5 \cdot 10}{2\pi \cdot 20 \cdot 10^{-2}} = \frac{4 \cdot 5}{2 \cdot 2} \cdot 10^{-5} = 5 \cdot 10^{-5} \frac{\text{N}}{\text{m}}$$

$$\text{b) } dL = F(x) \cdot dx \Rightarrow \int_0^L dL' = \int_{d_1}^{d_2} F(x) \cdot dx \Rightarrow L = \int_{d_1}^{d_2} \frac{\mu_0 \cdot I_1 \cdot I_2}{2\pi \cdot x} L \cdot dx \Rightarrow$$

$$L = \int_{d_1}^{d_2} \frac{\mu_0 \cdot I_1 \cdot I_2}{2\pi \cdot x} L \cdot dx = \frac{\mu_0 \cdot I_1 \cdot I_2}{2\pi} L \cdot \int_{d_1}^{d_2} \frac{dx}{x} = \frac{\mu_0 \cdot I_1 \cdot I_2}{2\pi} L \cdot \ln(x) \Big|_{d_1}^{d_2} \Rightarrow L = \frac{\mu_0 \cdot I_1 \cdot I_2}{2\pi} L \cdot \ln\left(\frac{d_2}{d_1}\right)$$

$$\frac{L}{L} = \frac{\mu_0 \cdot I_1 \cdot I_2}{2\pi} \cdot \ln\left(\frac{d_2}{d_1}\right) = \frac{4\pi \cdot 10^{-7} \cdot 5 \cdot 10}{2\pi} \cdot \ln\left(\frac{30}{20}\right) = 0.405465 \cdot 10^{-5} \quad \frac{L}{L} = 4.05465 \cdot 10^{-6} \quad \frac{J}{m}$$

34. An electric current with $I = 10$ A is flowing through a straight line infinite long conductor which is placed in the plane of a rectangular frame parallel with two of his sides, like in the figure. We know the $a = c = 20$ cm and $b = 30$ cm. Calculate: a) the magnetic flux through the rectangular frame; b) the force that acts on each side of the frame; c) the total force that acts on the frame when through this a $I' = 5$ A electric current is passing through. What is the sense of this electric current to observe an attraction force?

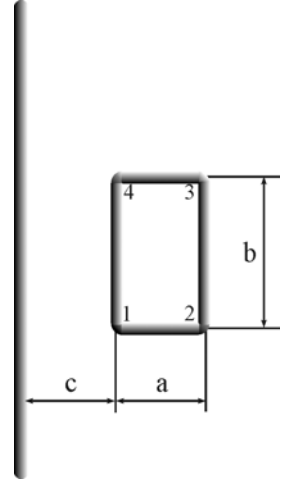

R: a)

$$d\Phi = \vec{B} \cdot d\vec{S} \Rightarrow \int_0^\Phi d\Phi' = \int_S \vec{B} \cdot d\vec{S} \Rightarrow \Phi = \int_c^{c+a} B \cdot b \cdot dr = b \cdot \int_c^{c+a} \frac{\mu_0 I}{2\pi r} \cdot dr = b \cdot \frac{\mu_0 I}{2\pi} \cdot \int_c^{c+a} \frac{dr}{r}$$

$$\Phi = \frac{\mu_0 I \cdot b}{2\pi} \cdot \ln\left(\frac{c+a}{c}\right) = \frac{4\pi \cdot 10^{-7} \cdot 10 \cdot 0.3}{2\pi} \cdot \ln\left(\frac{40}{20}\right) = 4.15888 \cdot 10^{-7} \text{ Wb}$$

$$b) \quad dF = I' \cdot B \cdot dl \Rightarrow \int_0^{F_{\alpha\beta}} dF = \int_\alpha^\beta I' \cdot B \cdot dl \Rightarrow F_{\alpha\beta} = I' \cdot \int_\alpha^\beta B \cdot dl$$

$$F_{12} = -F_{34} = I' \cdot \int_c^{c+a} \frac{\mu_0 I}{2\pi r} \cdot dr = \frac{\mu_0 I' \cdot I}{2\pi} \cdot \ln\left(\frac{c+a}{c}\right) = \frac{4\pi \cdot 10^{-7} \cdot 10 \cdot 5}{2\pi} \cdot \ln\left(\frac{40}{20}\right) = 6.93147 \cdot 10^{-6} \text{ N}$$

$$F_{23} = I' \cdot \int_0^b \frac{\mu_0 I}{2\pi(c+a)} \cdot dr = \frac{\mu_0 I' \cdot I}{2\pi} \cdot \frac{b}{c+a} = \frac{4\pi \cdot 10^{-7} \cdot 5 \cdot 10}{2\pi} \cdot \frac{30}{40} = 7.5 \cdot 10^{-6} \text{ N}$$

$$F_{41} = I' \cdot \int_0^b \frac{\mu_0 I}{2\pi c} \cdot dr = \frac{\mu_0 I' \cdot I}{2\pi} \cdot \frac{b}{c} = \frac{4\pi \cdot 10^{-7} \cdot 5 \cdot 10}{2\pi} \cdot \frac{30}{20} = 15 \cdot 10^{-6} \text{ N}$$

$$\vec{F} = \vec{F}_{12} + \vec{F}_{23} + \vec{F}_{34} + \vec{F}_{41}$$

$$c) \quad F = F_{23} - F_{41} = \frac{\mu_0 I' \cdot I}{2\pi} \cdot \left[\frac{b}{c+a} - \frac{b}{c} \right] = -\frac{\mu_0 I' \cdot I}{2\pi} \cdot b \cdot \frac{a}{c(c+a)} = -\frac{\mu_0 I' \cdot I}{2\pi} \cdot b \cdot \frac{a}{2a^2}$$

$$F = -\frac{\mu_0 I' \cdot I}{4\pi} \cdot \frac{b}{a} = -\frac{4\pi \cdot 10^{-7} \cdot 5 \cdot 10}{4\pi} \cdot \frac{30}{20} = 7.5 \cdot 10^{-6} \text{ N}$$

35. The electric current intensity that flow through a conductor is time dependent according to the following law: $I(t) = 2+3t+t^2$. Calculate:

- The electric charge that pass through circuit during the time from $t_1 = 2$ s to $t_2 = 5$ s.
- The electric current intensity of a constant current, which leads to the same amount of electrical charge in the given time.

R:

$$a) \quad I = \frac{dQ}{dt} \Rightarrow Q = \int dQ = \int_{t_1}^{t_2} I \cdot dt = \int_{t_1}^{t_2} (2 + 3t + t^2) \cdot dt$$

$$Q = \left(2t + \frac{3t^2}{2} + \frac{t^3}{3} \right) \Big|_{t_1}^{t_2} = \left(2t_2 + \frac{3t_2^2}{2} + \frac{t_2^3}{3} \right) - \left(2t_1 + \frac{3t_1^2}{2} + \frac{t_1^3}{3} \right)$$

$$= \left(2 \cdot 5 + \frac{3 \cdot 5^2}{2} + \frac{5^3}{3} \right) - \left(2 \cdot 2 + \frac{3 \cdot 2^2}{2} + \frac{2^3}{3} \right) = 89.166 - 12.666 = 76.5$$

$$Q = 76.5 \text{ C}$$

$$b) \quad I_0 = \frac{Q}{\Delta t} = \frac{Q}{t_2 - t_1} = \frac{76.5}{5 - 2} = 25.5 \text{ A}$$

36. The wave function associated with a particle which describe the quantum behavior inside of an box with infinite walls is: $\Psi_n(x) = A \sin\left(n \frac{\pi}{a} x\right)$, where a is the box width. Using the probabilistic interpretation of the wave function and the atemporal Schrödinger equation calculate: a) the normalization constant; b) the particles energy for $a = 2 \text{ \AA}$, $m = 9.1 \times 10^{-31} \text{ kg}$ and $n = 1, 2, 3, \dots$

R: a) The normalized probability is mathematically given by:

$$\int dP = 1 \text{ and using the relation } dP = |\Psi(x)|^2 dx \text{ (Copenhagen interpretation of wave function)}$$

$$\int_0^1 dP = 1 \Rightarrow \int_{-\infty}^{+\infty} |\Psi(x)|^2 dx = 1 \Rightarrow \int_{-\infty}^{+\infty} A^2 \sin^2\left(n \frac{\pi}{a} x\right) dx = A^2 \int_{-\infty}^{+\infty} \sin^2\left(n \frac{\pi}{a} x\right) dx$$

$$= A^2 \int_0^a \frac{1 - \cos\left(\frac{2n\pi}{a} x\right)}{2} dx = \frac{A^2}{2} \left[a - \int_0^a \cos\left(\frac{2n\pi}{a} x\right) dx \right] = \frac{A^2}{2} \left[a - \frac{a}{2n\pi} \sin\left(\frac{2n\pi}{a} x\right) \Big|_0^a \right]$$

$$\Rightarrow \frac{A^2}{2} a = 1 \Rightarrow A = \sqrt{\frac{2}{a}}$$

$$A = \sqrt{\frac{2}{a}} = \sqrt{\frac{2}{2 \cdot 10^{-10}}} \Rightarrow A = 10^5 \text{ m}^{-1/2}$$

b) $\frac{d^2\Psi}{dx^2} + \frac{2m}{\hbar^2}(E-U)\Psi = 0$ Schrödinger's equation

$$\frac{d\Psi}{dx} = A \frac{n\pi}{a} \cos\left(\frac{n\pi}{a}x\right) \quad \frac{d^2\Psi}{dx^2} = -A \left(\frac{n\pi}{a}\right)^2 \sin\left(\frac{n\pi}{a}x\right) \quad \text{and } U = 0$$

Schrödinger's equation became:

$$-A \left(\frac{n\pi}{a}\right)^2 \sin\left(\frac{n\pi}{a}x\right) + \frac{2m}{\hbar^2}EA \sin\left(\frac{n\pi}{a}x\right) = 0$$

$$-A \left(\frac{n\pi}{a}\right)^2 + \frac{2m}{\hbar^2}EA = 0 \Rightarrow \frac{2m}{\hbar^2}E = \frac{n^2\pi^2}{a} \Rightarrow E_n = \frac{\hbar^2\pi^2}{2ma}n^2$$

$$\frac{\hbar^2}{8ma} = \frac{(6.6 \cdot 10^{-34})^2}{8 \cdot 9.1 \cdot 10^{-31} \cdot (2 \cdot 10^{-10})^2} = \frac{6.6^2}{8 \cdot 9.1 \cdot 2} \frac{10^{-68}}{10^{-51}} = 1.495 \cdot 10^{-18} (J) = 9.35 (eV)$$

$$E_1 = \frac{\hbar^2\pi^2}{2ma}1^2 = 9.35 (eV) \quad E_2 = \frac{\hbar^2\pi^2}{2ma}2^2 = 37.4 (eV) \quad E_3 = \frac{\hbar^2\pi^2}{2ma}3^2 = 84.1 (eV)$$

37. An atom from a Si crystalline network can be considered as a quantum particles inside a potential field of elastic forces $U(x) = kx^2/2$ which oscillate with the frequency $\nu = 2.5 \times 10^{13}$ Hz. The wave function in fundamental state is $\Psi(x) = Ae^{-\alpha x^2}$. Use the Schrödinger equation to calculate: a) the constant α and b) the particles energy if the atom mass is $m = 38.2 \times 10^{-28}$ kg.

R: a) $\Psi(x) = Ae^{-\alpha x^2} \quad \frac{d\Psi}{dx} = 2A \cdot \alpha \cdot x \cdot e^{-\alpha x^2} \quad \text{and} \quad \frac{d^2\Psi}{dx^2} = 4A\alpha^2 x^2 e^{-\alpha x^2} - 2A\alpha e^{-\alpha x^2}$

$$4A\alpha^2 x^2 e^{-\alpha x^2} - 2A\alpha e^{-\alpha x^2} + \frac{2m}{\hbar^2} \left(E - \frac{kx^2}{2} \right) A e^{-\alpha x^2} = 0$$

$$\left(4\alpha^2 - \frac{2m}{\hbar^2} \frac{k}{2} \right) x^2 + \left(\frac{2m}{\hbar^2} E - 2\alpha \right) = 0 \quad \text{for any } x \text{ values.}$$

$$\begin{cases} \left(4\alpha^2 - \frac{2m}{\hbar^2} \frac{k}{2} \right) = 0 \\ \left(\frac{2m}{\hbar^2} E - 2\alpha \right) = 0 \end{cases} \quad \text{from where} \quad \begin{cases} \alpha = \frac{\sqrt{mk}}{2\hbar} \\ E = \frac{\alpha\hbar^2}{m} \end{cases} \quad \text{and}$$

$$\alpha = \frac{\sqrt{mk}}{2\hbar} = \frac{m}{2\hbar} \sqrt{\frac{k}{m}} = \frac{m\omega}{2\hbar} = \frac{m2\pi\nu}{2\frac{h}{2\pi}} = \frac{2\pi^2 m\nu}{h}$$

$$\alpha = \frac{2\pi^2 38.2 \cdot 10^{-27} 2.5 \cdot 10^{13}}{6.6 \cdot 10^{-34}} = \frac{2\pi^2 38.2 \cdot 2.5 \cdot 10^{-27} \cdot 10^{13}}{6.6 \cdot 10^{-34}} = 2.856 \cdot 10^{22} \text{ m}^{-2}$$

$$E = \frac{\sqrt{mk}}{2\hbar} \frac{\hbar^2}{m} = \frac{\hbar}{2} \sqrt{\frac{k}{m}} = \frac{\hbar\omega}{2} = \frac{h\nu}{2}$$

The expression of energy of quantum oscillator is:

$$E_n = \left(n + \frac{1}{2}\right)h\nu \quad \text{results the fundamental state with } n = 0.$$

$$E = \frac{h\nu}{2} = \frac{6.6 \cdot 10^{-34} \cdot 2.5 \cdot 10^{13}}{2} = 8.25 \cdot 10^{-21} (J) = 5.15 \cdot 10^{-2} (eV)$$

38. A particle of mass $m = 10^{-28}$ kg is described by the wave function: $\Psi(x,t) = Ae^{-i(\omega t - kx)}$, with the normalization constant $A = 10^5$ ($\text{m}^{1/2}$), $\omega = \pi 10^{15}$ (rad/s) and $k = \pi 10^{10}$ (m^{-1}). Applying the quantum mechanical operators calculate the particles: energy, momentum (impulse), kinetically and potential energy.

$$\text{R: a) } \hat{E} = i\hbar \frac{\partial}{\partial t} \quad \text{and} \quad \hat{E}\Psi = E\Psi$$

$$i\hbar \frac{\partial \Psi}{\partial t} = -i^2 \hbar A \omega e^{-i(\omega t - kx)} = \hbar \omega A e^{-i(\omega t - kx)} = \hbar \omega \Psi = E\Psi \quad E = \hbar \omega = \frac{6.6 \cdot 10^{-34} \pi \cdot 10^{15}}{2\pi}$$

$$E = 3.310^{-19} (J) = 2.06 (eV)$$

$$\text{b) } \hat{p} = \frac{\hbar}{i} \frac{\partial}{\partial x} \quad \text{and} \quad \hat{p}\Psi = p\Psi$$

$$\hat{p}\Psi = \frac{\hbar}{i} \frac{\partial \Psi}{\partial x} = \frac{\hbar}{i} A i k \omega e^{-i(\omega t - kx)} = k\hbar A e^{-i(\omega t - kx)} = k\hbar \Psi = p\Psi$$

$$p = k\hbar = \frac{\pi \cdot 10^{10} \cdot 6.6 \cdot 10^{-34}}{2\pi} = 3.3 \cdot 10^{-24} \text{ kg} \frac{\text{m}}{\text{s}}$$

$$E_c = \frac{mv^2}{2} \Rightarrow \hat{T} = \frac{\hat{p}^2}{2m} = -\frac{\hbar^2}{2m} \frac{\partial^2}{\partial x^2}$$

$$T = \frac{p^2}{2m} = \frac{(3.3 \cdot 10^{-24})^2}{2 \cdot 10^{-28}} = \frac{3.3^2}{2} \cdot 10^{-20} = 5.445 \cdot 10^{-20} (J) = 0.34 (eV)$$

$$E = T + U \Rightarrow U = E - T = 2.06 - 0.34 = 1.72 (eV)$$